



AUTOCLIMA
QUALITY & COMFORT

**RISCALDATORI
GHIBLI e SCIROCCO**

H 50 - H 75



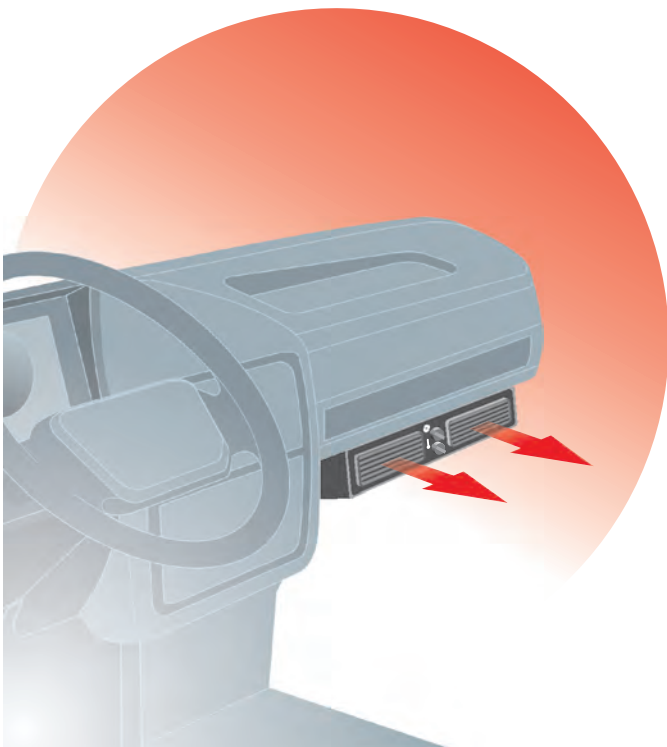

DENVER
AIR CONDITIONERS



 Riscaldatori per montaggio sottopancia o sottotetto, 3 velocità di ventilazione.

 Rechauffeurs pour montage sous planche ou sous plafond, 3 vitesses de ventilation.

 Heaters under dashboard mounted (or under-roof), 3 blower speed.

 Heizungen für die Montage unterhalb vom Armaturenbrett oder vom Dach, 3 Gebläsegeschwindigkeiten.

 Calefactores para montar debajo del salpicadero (o bajo del techo), 3 velocidades del ventilador.

RISCALDATORE H 50

12V cod. 15151005/2 - 24V cod. 15151006/2



RISCALDATORE H 75

12V cod. 15151002 - 24V cod. 15151003



GHIBLI H 50

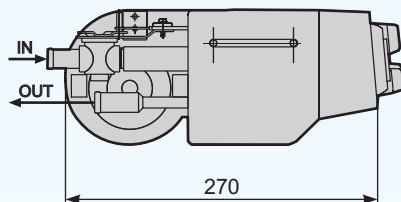
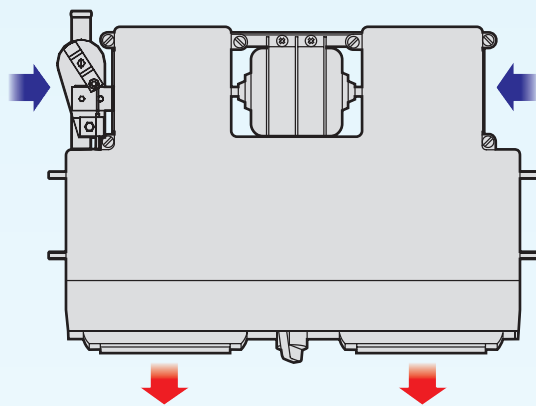
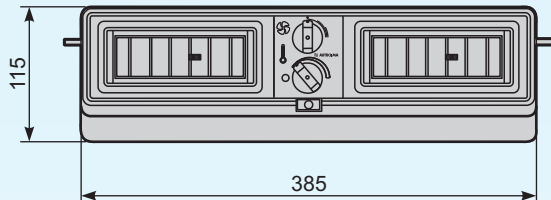

SCIROCCO H 75

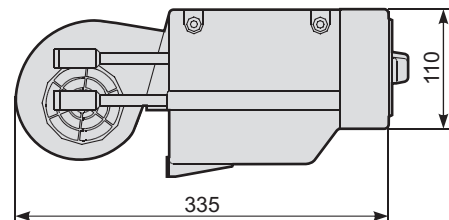
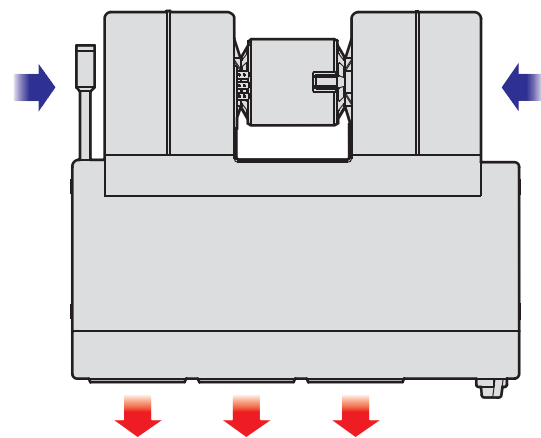
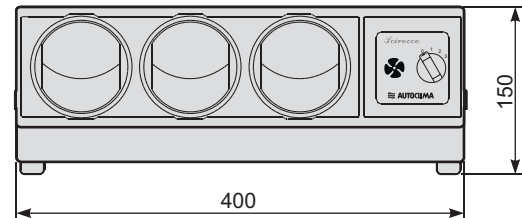

Dati tecnici nominali	Données techniques nominales	Nominal technical data	Technische Nominal-Eigenheiten	Datos técnicos	H 50 - H 75
<ul style="list-style-type: none"> • Potenza riscaldamento • Tensione alimentazione • Assorbimento elettrico • Portata aria • Peso 	<ul style="list-style-type: none"> • Puissance chauffage • Tension d'alimentation • Absorption électrique • Débit air • Poids 	<ul style="list-style-type: none"> • Heating capacity • Working voltage • Power consumption • Air flow • Weight 	<ul style="list-style-type: none"> • Heizleistung • Spannung • Stromverbrauch • Gebläseleistung • Gewicht 	<ul style="list-style-type: none"> • Potencia calefactora • Tension de alimentacion • Intensidad absorbida • Caudal de aire • Peso 	<p>5 kW (H 50) - 7,7 kW (H 75) 12Vc.c / 24Vc.c 12A (12V) / 6A (24V) 400 m³/h (H 50) - 450 m³/h (H 75) 5,5 Kg</p>

La nostra società si riserva il diritto di migliorare e modificare ciascuno dei modelli illustrati, senza alcun preavviso.

Notre Société se réserve le droit d'améliorer et de modifier sans aucun préavis chacun des modèles ci-illustrés.

The company reserves the right to modify any design in the model without prior notice as per our policy of continuous improvement of design, quality and performance.

Unsere Firma behält sich das Recht vor, jeden Modell hier erläutert ohne Vorankündigung zu ändern und verbessern.

La compañía se reserva el derecho a modificar cualquier diseño en los modelos sin previo aviso debido a la política de continua mejora en el diseño, en la calidad y en el rendimiento



Autoclima S.p.A. - 10020 Cambiano (TO) - ITALY
 Via Cavalieri di Vittorio Veneto, 15 - Tel. 011.94.43.210 - Fax 011.94.43.230
 Internet: <http://www.autoclima.com> e-mail: sales@autoclima.com

STAMPATO IN ITALIA - RIPRODUZIONE VIETATA

Cod.80819160