



**AUTOCLIMA**  
QUALITY & COMFORT

## EVAPORATORE VERTICAL Heavy Duty

**EV 40/1 - EVH 40/1**





**DENVER**  
AIR CONDITIONERS



 Evaporatore verticale, disegnato per l'installazione contro la parete posteriore della cabina. Costruzione robusta per impieghi gravosi. Disponibile anche con riscaldamento.

 Evaporateur vertical conçu pour l'installation contre la paroi postérieure de la cabine. Construction solide pour emplois lourds. Disponible avec chauffage aussi.

 Vertical evaporator designed for installation against the rear wall of the cab. Heavy duty construction. Also available with heating option.

 Senkrechter Verdampfer für die installation an der Hinterwand der Kabine. Starke Struktur für schwere Anwendungen. Auch mit Heizung lieferbar.

 Evaporador vertical diseñado para instalación contra la pared trasera de la cabina. De construcción robusta para empleos gravosos. También disponible con la opción de calefactor.

**EVAPORATORE (A PARETE) EV 40/1**

12V cod.2020189132 + 2027082107.2

24V cod.2020189133 + 2027082107.2



**EVAPORATORE (A PARETE) EVH 40/1**

12V cod.2020189134 + 2027082107.2

24V cod.2020189135 + 2027082107.2

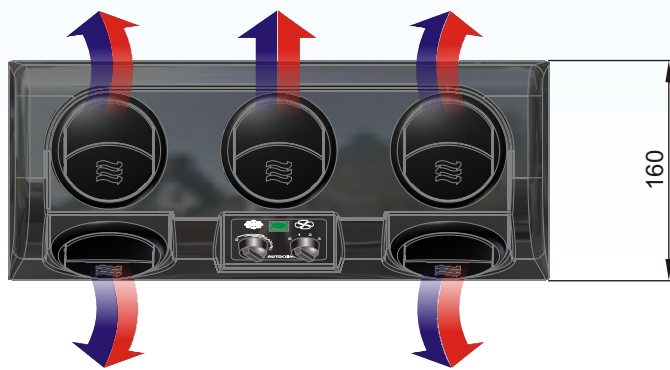
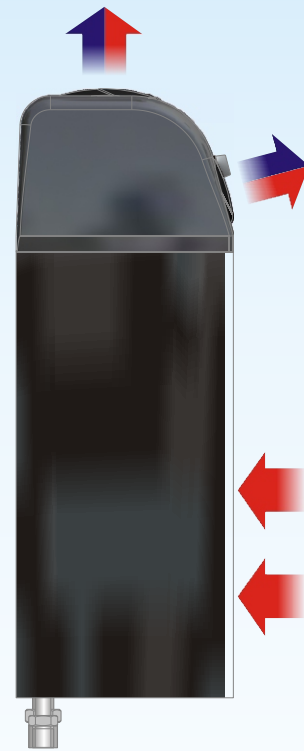
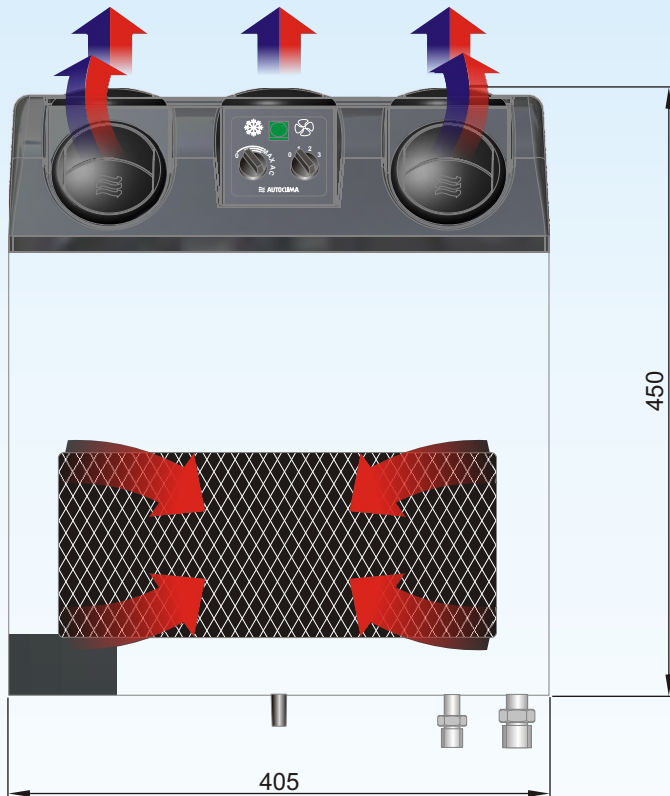

Dati tecnici nominali	Données techniques nominaux	Nominal technical data	Technische Nominal-Eigenheiten	Datos técnicos	<b>EV 40/1 - EVH 40/1</b>
• Potenza frigorifera	• Puissance frigorifique	• Cooling capacity	• Kälteleistung	• Potencia frigorífica	4 kW
• Potenza riscaldamento	• Puissance chauffage	• Heating capacity	• Heizleistung	• Potencia calefactora	3,5 kW
• Tensione alimentazione	• Tension d'alimentation	• Working voltage	• Spannung	• Tension de alimentacion	12Vc.c / 24Vc.c
• Assorbimento elettrico	• Absorption électrique	• Power consumption	• Stromverbrauch	• Intensidad absorbida	13A (12V) / 6,5A (24V)
• Portata aria	• Débit air	• Air flow	• Gebläseleistung	• Caudal de aire	450 m <sup>3</sup> /h
• Refrigerante	• Réfrigérant	• Coolant	• Kühlmittel	• Refrigerador	R134a
• Peso	• Poids	• Weight	• Gewicht	• Peso	14 Kg

La nostra società si riserva il diritto di migliorare e modificare ciascuno dei modelli illustrati, senza alcun preavviso.

Notre Société se réserve le droit d'améliorer et de modifier sans aucun préavis chacun des modèles ci-illustrés.

The company reserves the right to modify any design in the model without prior notice as per our policy of continuous improvement of design, quality and performance.

Unsere Firma behält sich das Recht vor, jeden Modell hier erläutert ohne Vorankündigung zu ändern und verbessern.

La compañía se reserva el derecho a modificar cualquier diseño en los modelos sin previo aviso debido a la política de continua mejora en el diseño, en la calidad y en el rendimiento



Autoclima S.p.A. - 10020 Cambiano (TO) - ITALY  
 Via Cavalieri di Vittorio Veneto, 15 - Tel. 011.94.43.210 - Fax 011.94.43.230  
 Internet: <http://www.autoclima.com> e-mail: [sales@autoclima.com](mailto:sales@autoclima.com)

STAMPATO IN ITALIA - RIPRODUZIONE VIETATA

Cod. \_\_\_\_\_



**AUTOCLIMA**  
QUALITY & COMFORT

## EVAPORATORE VERTICAL Heavy Duty

**EV 40/1 - EVH 40/1**



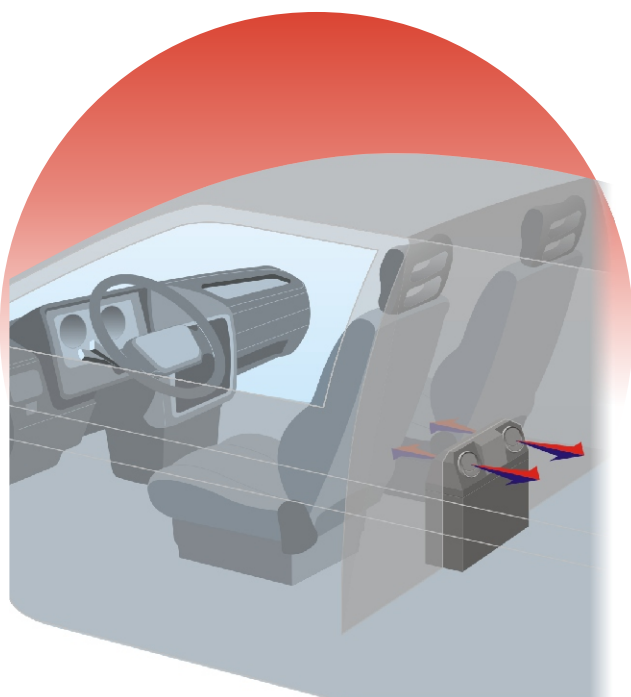

**DENVER**  
AIR CONDITIONERS



 Evaporatore studiato per l'installazione tra due vani adiacenti. Distribuzione dell'aria attraverso bocchette regolabili. Disponibile anche con riscaldamento.

 Evaporateur conçu pour l'installation entre deux compartiments attenants. Distribution de l'air à travers des diffuseurs réglables. Disponible avec chauffage aussi.

 Evaporator designed for installation between 2 compartments. Air distribution through adjustable louvers. Also available with heating option.

 Verdampfer für die Montage zwischen 2 nebeneinanderliegenden Räume. Luftverteilung durch regelbare Düsen. Auch mit Heizung lieferbar.

 Evaporador diseñado para instalación entre dos compartimentos. Distribución de aire regulable mediante toberas. También disponible con la opción de calefactor.

EVAPORATORE (TWO SIDES)

EV 40/1

12V cod.2020189132 + 2027082278

24V cod.2020189133 + 2027082278



EVAPORATORE (TWO SIDES)

EVH 40/1

12V cod.2020189134 + 2027082278

24V cod.2020189135 + 2027082278

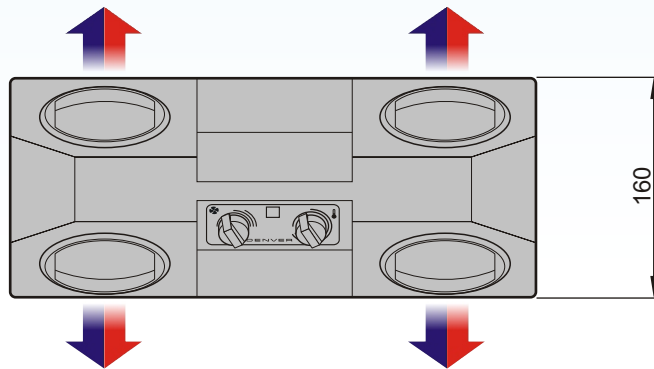
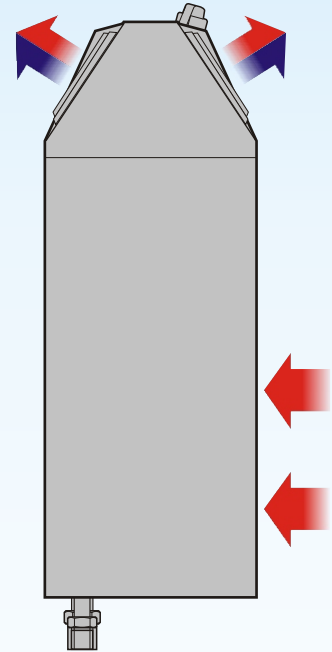
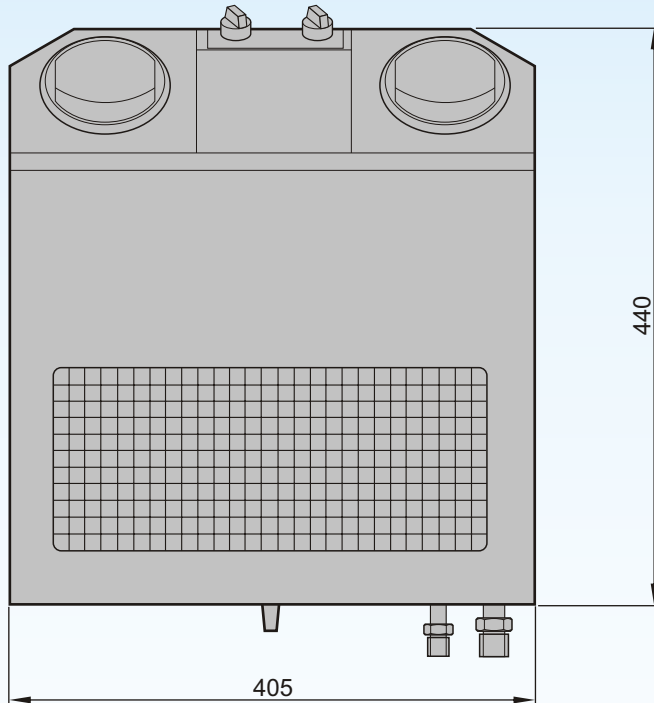

Dati tecnici nominali	Données techniques nominaux	Nominal technical data	Technische Nominal-Eigenheiten	Datos técnicos	EV 40/1 - EVH 40/1
• Potenza frigorifera	• Puissance frigorifique	• Cooling capacity	• Kälteleistung	• Potencia frigorífica	4 kW
• Potenza riscaldamento	• Puissance chauffage	• Heating capacity	• Heizleistung	• Potencia calefactora	3,5 kW
• Tensione alimentazione	• Tension d'alimentation	• Working voltage	• Spannung	• Tension de alimentacion	12Vc.c / 24Vc.c
• Assorbimento elettrico	• Absorption électrique	• Power consumption	• Stromverbrauch	• Intensidad absorbida	13A (12V) / 6,5A (24V)
• Portata aria	• Débit air	• Air flow	• Gebläseleistung	• Caudal de aire	450 m <sup>3</sup> /h
• Refrigerante	• Réfrigérant	• Coolant	• Kühlmittel	• Refrigerador	R134a
• Peso	• Poids	• Weight	• Gewicht	• Peso	14 Kg

La nostra società si riserva il diritto di migliorare e modificare ciascuno dei modelli illustrati, senza alcun preavviso.

Notre Société se réserve le droit d'améliorer et de modifier sans aucun préavis chacun des modèles ci-illustrés.

The company reserves the right to modify any design in the model without prior notice as per our policy of continuous improvement of design, quality and performance.

Unsere Firma behält sich das Recht vor, jeden Modell hier erläutert ohne Vorankündigung zu ändern und verbessern.

La compañía se reserva el derecho a modificar cualquier diseño en los modelos sin previo aviso debido a la política de continua mejora en el diseño, en la calidad y en el rendimiento



Autoclima S.p.A. - 10020 Cambiano (TO) - ITALY  
Via Cavalieri di Vittorio Veneto, 15 - Tel. 011.94.43.210 - Fax 011.94.43.230  
Internet: <http://www.autoclima.com> e-mail: [sales@autoclima.com](mailto:sales@autoclima.com)

STAMPATO IN ITALIA - RIPRODUZIONE VIETATA

Cod. \_\_\_\_\_





**AUTOCLIMA**  
QUALITY & COMFORT

## EVAPORATORE VERTICAL Heavy Duty

**EV 40/1 - EVH 40/1**



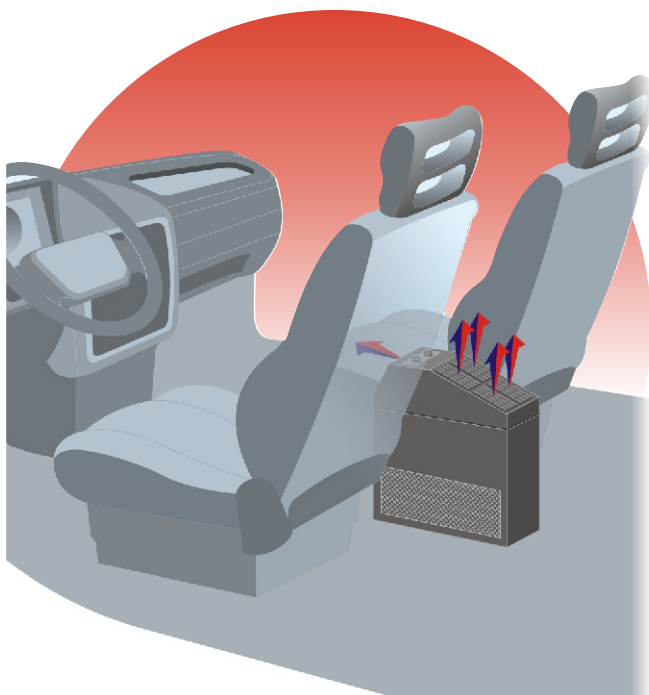

**DENVER**  
AIR CONDITIONERS



 Per il montaggio tra due sedili, 3 velocità di ventilazione, termostato regolabile, costruzione robusta per impieghi gravosi. Disponibile anche con riscaldamento.

 Pour le montage entre 2 sièges, 3 vitesses de ventilation, thermostat réglable, construction solide pour emplois lourds. Disponible avec chauffage aussi.

 Designed for installation between 2 seats, 3 speed blower, adjustable thermostat, heavy duty construction. Also available with heating option.

 Für die Montage zwischen 2 Sitzen, 3 Gebläsegeschwindigkeiten, Stufenlos regelbarer Thermostat, starke Struktur für schwere Anwendungen. Auch mit Heizung lieferbar.

 Evaporador para instalación entre dos asientos, tres velocidades del ventilador, termostato regulable. De construcción robusta para empleos gravosos. También disponible con la opción de calefactor.

**EVAPORATORE (CENTRALE)**

**EV 40/1**

12V cod.2020189132 + 2027082109

24V cod.2020189133 + 2027082109



**EVAPORATORE (CENTRALE)**

**EVH 40/1**

12V cod.2020189134 + 2027082109

24V cod.2020189135 + 2027082109

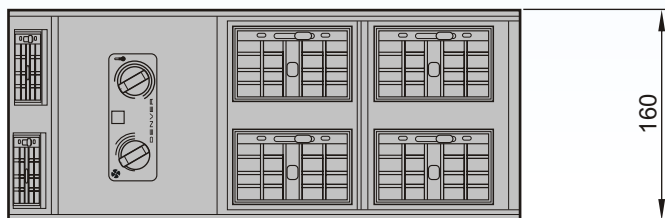
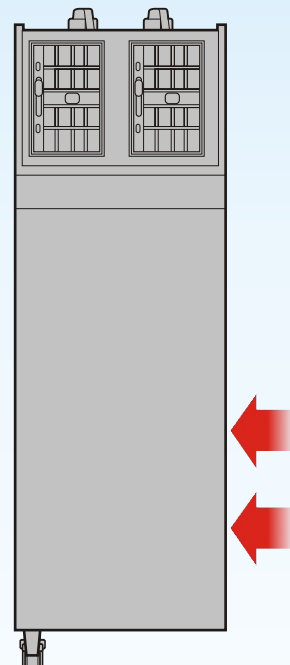
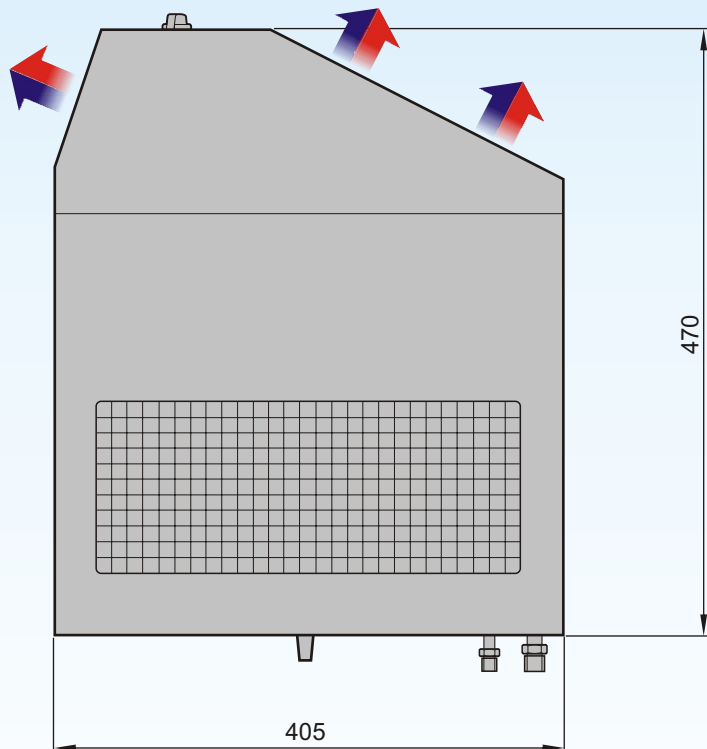

Dati tecnici nominali	Données techniques nominaux	Nominal technical data	Technische Nominal-Eigenheiten	Datos técnicos	<b>EV 40/1 - EVH 40/1</b>
• Potenza frigorifera	• Puissance frigorifique	• Cooling capacity	• Kälteleistung	• Potencia frigorífica	4 kW
• Potenza riscaldamento	• Puissance chauffage	• Heating capacity	• Heizleistung	• Potencia calefactora	3,5 kW
• Tensione alimentazione	• Tension d'alimentation	• Working voltage	• Spannung	• Tension de alimentación	12Vc.c / 24Vc.c
• Assorbimento elettrico	• Absorption électrique	• Power consumption	• Stromverbrauch	• Intensidad absorbida	13A (12V) / 6,5A (24V)
• Portata aria	• Débit air	• Air flow	• Gebläseleistung	• Caudal de aire	450 m <sup>3</sup> /h
• Refrigerante	• Réfrigérant	• Coolant	• Kühlmittel	• Refrigerador	R134a
• Peso	• Poids	• Weight	• Gewicht	• Peso	14 Kg

La nostra società si riserva il diritto di migliorare e modificare ciascuno dei modelli illustrati, senza alcun preavviso.

Notre Société se réserve le droit d'améliorer et de modifier sans aucun préavis chacun des modèles ci-illustrés.

The company reserves the right to modify any design in the model without prior notice as per our policy of continuous improvement of design, quality and performance.

Unsere Firma behält sich das Recht vor, jeden Modell hier erläutert ohne Vorankündigung zu ändern und verbessern.

La compañía se reserva el derecho a modificar cualquier diseño en los modelos sin previo aviso debido a la política de continua mejora en el diseño, en la calidad y en el rendimiento



Autoclima S.p.A. - 10020 Cambiano (TO) - ITALY  
 Via Cavalieri di Vittorio Veneto, 15 - Tel. 011.94.43.210 - Fax 011.94.43.230  
 Internet: <http://www.autoclima.com> e-mail: [sales@autoclima.com](mailto:sales@autoclima.com)

STAMPATO IN ITALIA - RIPRODUZIONE VIETATA

Cod. \_\_\_\_\_



Centrale / Middle / Milieu / Mitte / Medio

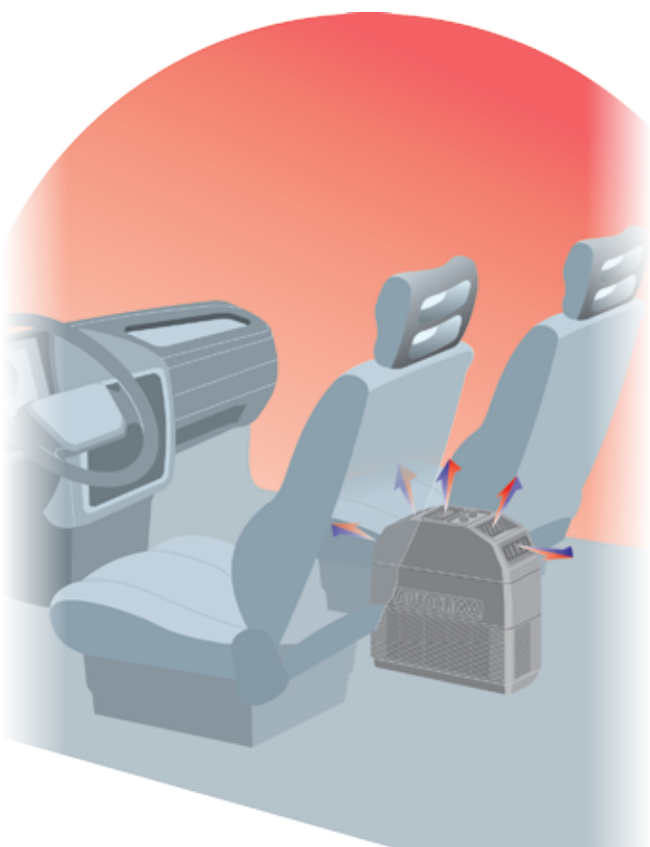







 Per il montaggio tra due sedili, 3 velocità di ventilazione, termostato regolabile. Disponibile anche con riscaldamento.

 Designed for installation between 2 seats, 3 speed blower, adjustable thermostat. Also available with heating option.

 Pour le montage entre 2 sièges, 3 vitesses de ventilation, thermostat réglable. Disponible avec chauffage aussi.

 Für die Montage zwischen 2 Sitzen, 3 Gebläsegeschwindigkeiten, Stufenlos regelbarer Thermostat. Auch mit Heizung lieferbar.

 Evaporador para instalación entre dos asientos, tres velocidades del ventilador, termostato regulable. También disponible con la opción de calefactor.

<b>EV 40/3</b>	EVAPORATORE (centrale) 12V		cod. 20201707
<b>EV 40/3</b>	EVAPORATORE (centrale) 24V		cod. 20201708
<b>EVH 40/3</b>	EVAPORATORE - RISC. (centrale) 12V	 	cod. 20201709
<b>EVH 40/3</b>	EVAPORATORE - RISC. (centrale) 24V	 	cod. 20201710

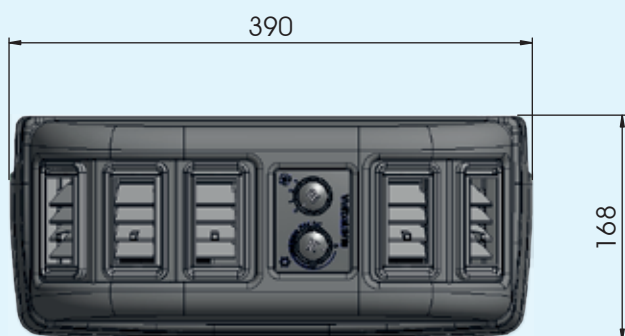
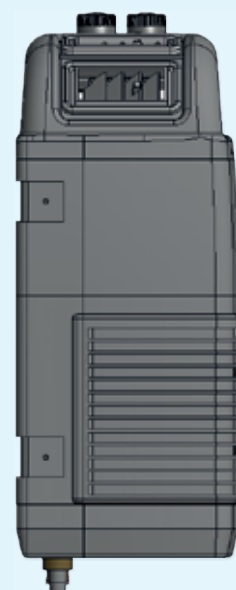
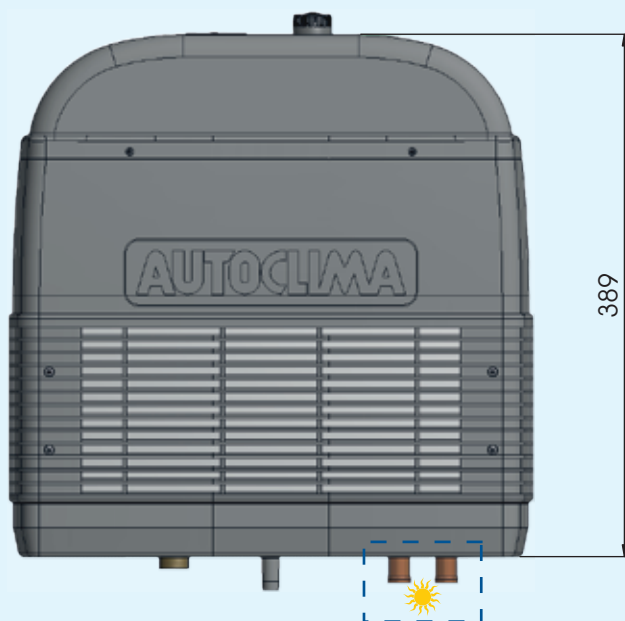

Dati tecnici nominali	Nominal technical data	Données techniques nominaux	Technische Nominal-Eigenheiten	Datos técnicos	EV 40/3 - EVH 40/3
• Potenza frigorifera	• Cooling capacity	• Puissance frigorifique	• Kühlleistung	• Potencia frigorífica	4,6 kW (EV) - 4,3 kW (EVH)
• Potenza riscaldamento	• Heating capacity	• Puissance chauffage	• Heizleistung	• Potencia calefacción	4,5 kW (EVH)
• Portata aria *	• Air flow *	• Débit air *	• Luftleistung *	• Caudal de aire *	530 m³/h (EV) - 450 m³/h (EVH)
* (pressione statica = 0 Pa)	* (static pressure = 0 Pa)	* (pression statique = 0 Pa)	* (statischer Druck = 0 Pa)	* (presión estática = 0 Pa)	
• Tensione di alimentazione	• Working voltage	• Tension de alimentation	• Stromspannung	• Tensión de alimentación	12 V cc / 24 V cc
• Assorbimento elettrico	• Power consumption	• Absorption électrique	• Elektrische Absorption	• Absorción eléctrica	11 A @ 12V / 5,5 A @ 24 V
• Refrigerante	• Coolant	• Réfrigérant	• Kühlmittel	• Refrigerante	R134a
• Peso	• Weight	• Poids	• Gewicht	• Peso	7 kg (EV) - 7,5 kg (EVH)

La nostra società si riserva il diritto di migliorare e modificare ciascuno dei modelli illustrati, senza alcun preavviso.

Notre Société se réserve le droit d'améliorer et de modifier sans aucun préavis chacun des modèles ci-illustrés.

The company reserves the right to modify any design in the model without prior notice as per our policy of continuous improvement of design, quality and performance.

Unsere Firma behaltet sich das Recht vor, jeden Modell hier erlautet ohne Vorankündigung zu ändern und verbessern.

La compañía se reserva el derecho a modificar cualquier diseño en los modelos sin previo aviso debido a la política de continua mejora en el diseño, en la calidad y en el rendimiento.



**AUTOCLIMA S.p.A.**

Via Cavalieri di Vittorio Veneto, 15 - 10020 Cambiano (TO) - ITALY

Tel. +39 011 9443210 - Fax +39 011 9443230

sales@autoclima.com - www.autoclima.com





**AUTOCLIMA**  
QUALITY & COMFORT

## EVAPORATORE / EVAP.-RISC. VERTICAL 3

### EV 40/3 - EVH 40/3



Evaporatore verticale, disegnato per l'installazione contro la parete posteriore della cabina. Disponibile anche nella versione con funzione di riscaldamento; con comandi manuali o con centralina elettronica di controllo.



Evaporateur vertical conçu pour l'installation contre la paroi postérieure de la cabine. Egalement disponible avec fonction de chauffage; avec commandes manuelles ou centrale digitale de contrôle.



Vertical evaporator designed for installation against the rear wall of the cab. Available with additional heating function too; with manual controls or digital control unit.



Senkrechter Verdampfer für die installation an der Hinterwand der Kabine. Verfügbare auch mit Heizungsfunktion; mit manuelle Bedienungen oder digitales Steuergerät lieferbar.



Evaporador vertical diseñado para instalación contra la pared trasera de la cabina. También disponible con función de calefacción; con controles manuales o con centralita digital de control.

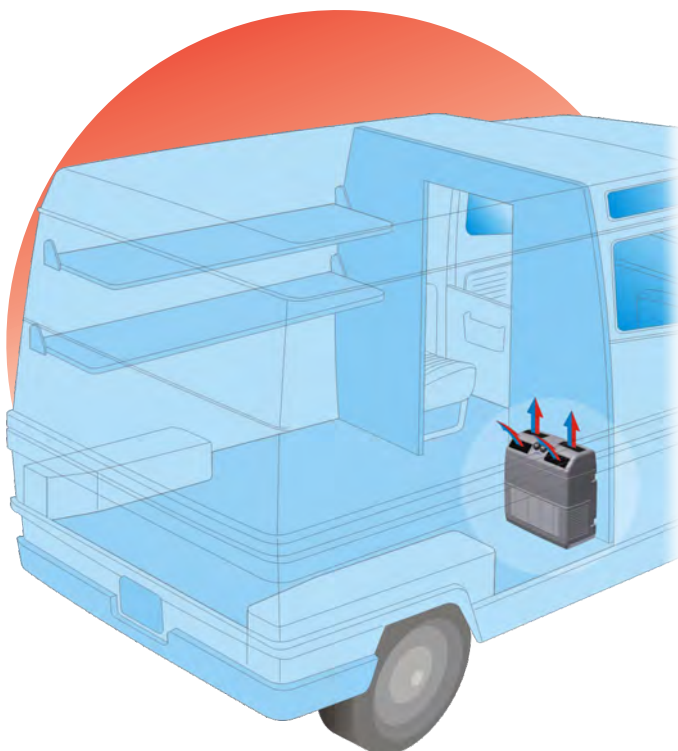

EVAPORATORE (a parete) EV 40/3

cod. 20201540 (12V) / cod. 20201541 (24V)



EVAPORATORE (a parete) EVH 40/3

cod. 20201542 (12V) / cod. 20201543 (24V)

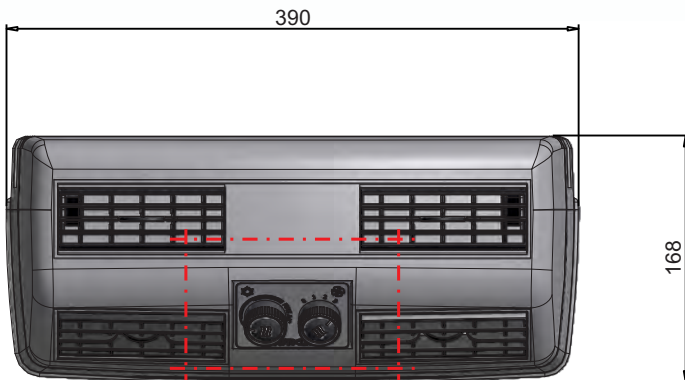
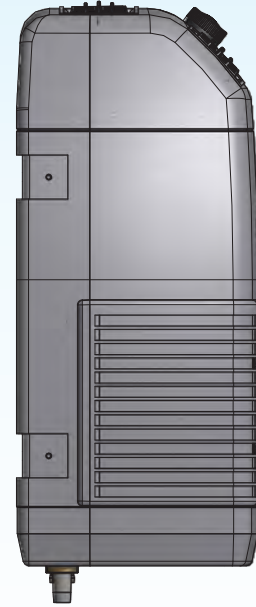
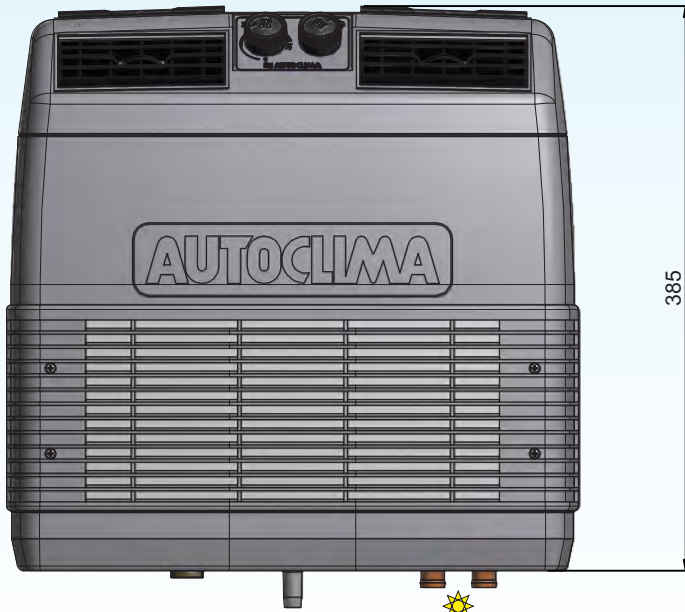

COMANDI  
COMMANDES  
CONTROLS  
KONTROLLEN  
CONTROLES

Comandi manuali  
Commandes manuelles  
Manual controls  
Manuelle Kontrollen  
Controles manuales



Centralina digitale di controllo (OPTIONAL)  
Centrale digitale de contrôle (OPTIONNEL)  
Digital control unit (OPTIONAL)  
Digitales Steuergerät (OPTIONAL)  
Centralita digital de control (OPCIONAL)



(EVH 40/3)

Dati tecnici nominali	Données techniques nominaux	Nominal technical data	Technische Nominal-Eigenheiten	Datos técnicos	EV 40/3 - EVH 40/3
• Potenza frigorifera	• Puissance frigorifique	• Cooling capacity	• Kälteleistung	• Potencia frigorífica	4,6 kW (EV) - 4,3 kW (EVH)
• Potenza riscaldamento	• Puissance chauffage	• Heating capacity	• Heizleistung	• Potencia calefactora	4,5 kW (EVH)
• Tensione alimentazione	• Tension d'alimentation	• Working voltage	• Spannung	• Tension de alimentacion	12Vc.c / 24Vc.c
• Assorbimento elettrico	• Absorption électrique	• Power consumption	• Stromverbrauch	• Intensidad absorbida	13A (12V) / 7A (24V)
• Portata aria	• Débit air	• Air flow	• Gebläseleistung	• Caudal de aire	530 m <sup>3</sup> /h (EV) - 450 m <sup>3</sup> /h (EVH)
• Refrigerante	• Réfrigérant	• Coolant	• Kuehlmittel	• Refrigerador	R134a
• Peso	• Poids	• Weight	• Gewicht	• Peso	7 Kg (EV) - 7,5 Kg (EVH)

La nostra società si riserva il diritto di migliorare e modificare ciascuno dei modelli illustrati, senza alcun preavviso.

Notre Société se réserve le droit d'améliorer et de modifier sans aucun préavis chacun des modèles ci-illustrés.

The company reserves the right to modify any design in the model without prior notice as per our policy of continuous improvement of design, quality and performance.

Unsere Firma behält sich das Recht vor, jeden Modell hier erlautet ohne Vorankündigung zu ändern und verbessern.

La compañía se reserva el derecho a modificar cualquier diseño en los modelos sin previo aviso debido a la política de continua mejora en el diseño, en la calidad y en el rendimiento



Autoclima S.p.A. - 10020 Cambiano (TO) - ITALY  
Via Cavalieri di Vittorio Veneto, 15 - Tel. 011.94.43.210 - Fax 011.94.43.230  
Internet: <http://www.autoclima.com> e-mail: [sales@autoclima.com](mailto:sales@autoclima.com)

STAMPATO IN ITALIA - RIPRODUZIONE VIETATA

Cod. 80819202