



FROSTY 2000



 Il **Frosty 2000** è un refrigeratore sottotetto progettato per lavorare su temperature sia positive sia negative nelle celle isoterme medio-piccole di una vasta gamma di veicoli commerciali. Può essere fornito in versione **R134a** oppure **R404a**. E' **sempre dotato di DEFROST** a gas caldo per lo sbrinamento. Nella composizione base è presente il condensatore ante radiatore, il compressore specifico in base al veicolo, il cablaggio e il pannello di controllo di dimensioni compatte da posizionare nell'abitacolo. E' disponibile l'**omologazione ATP**. Una serie di **OPTIONAL** personalizzati completa l'offerta del prodotto.

 **Frosty 2000** is a mobile refrigerator designed to operate both above and below 0°C, in the insulated cells of light commercial vehicles. Available either with **R134a** or with **R404a** coolants. All models **include** the hot gas **DEFROST** kit. Basic configuration includes front radiator condenser, appropriate compressor, wiring and control panel. It can be supplied under **ATP rule** and a wide choice of **OPTIONS** is also available.

REFRIGERATORE FROSTY 2000 (R134a)

cod. 20201534 (12V)



REFRIGERATORE FROSTY 2000 (R404a)

cod. 20201559 (12V)

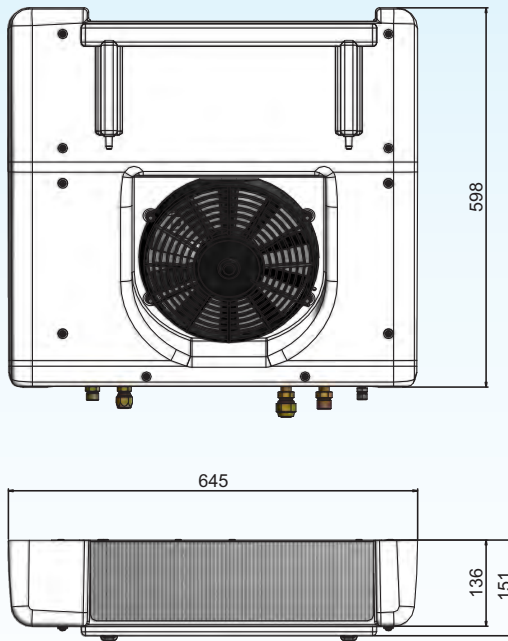

Pacchetto omologazione Type-approval pack A.T.P.	12121875 FROSTY 2000 12 V R134a	<ul style="list-style-type: none"> • 20201534 Refrigeratore Frosty • 30301239 Condensatore • 80821271 Kit cablaggi • 40405999 Compressore TM13 / TM15 (specifico per il veicolo) 	<ul style="list-style-type: none"> • 20201534 Refrigerator Frosty • 30301239 Condenser • 80821271 Wirings kit • 40405999 TM13 / TM15 compressore (specific for the vehicle)
	12121876 FROSTY 2000 12 V R404a	<ul style="list-style-type: none"> • 20201559 Refrigeratore Frosty • 30301239 Condensatore • 80821271 Kit cablaggi • 40405999 Compressore TM13 / TM15 (specifico per il veicolo) • 80821285 Kit sicurezza compressore 	<ul style="list-style-type: none"> • 20201559 Refrigerator Frosty • 30301239 Condenser • 80821271 Wirings kit • 40405999 TM13 / TM15 compressore (specific for the vehicle) • 80821285 Compressor safety kit
STRADA DIRECT DRIVE (12 V)	<ul style="list-style-type: none"> • 60600816 • 50500XXX • 80821XXX 	<ul style="list-style-type: none"> • Set di montaggio (tubi, raccordi e accessori per il collegamento della versione STRADA) • Staffaggio compressore specifico in base al veicolo • Kit raccordi al compressore specifici in base a compressore e veicolo 	<ul style="list-style-type: none"> • Mounting set (hoses, fittings and accessories to connect the DIRECT-DRIVE version) • Compressor brackets specific for the vehicle • Compressor fittings kit specific for the compressor and vehicle
STAND-BY STAND-BY (220 V)	<ul style="list-style-type: none"> • 40471015 • 40471016 • 60600817 • 60670251 	<ul style="list-style-type: none"> • Gruppo compressore (R134a) – motore elettrico • Gruppo compressore (R404a) – motore elettrico • Set di montaggio (tubi, raccordi e accessori per il collegamento della versione STAND-BY) • Carica batteria 12V (per il mantenimento della batteria del veicolo) 	<ul style="list-style-type: none"> • Compressor (R134a) – electric motor unit • Compressor (R404a) – electric motor unit • Mounting set (hoses, fittings and accessories to connect the STAND-BY version) • Battery charger 12V (for the maintenance of the vehicle battery)
Optional comuni Optional common	<ul style="list-style-type: none"> • 80821261 • 80821270 • 80821272 • 80821273 • 80821285 	<ul style="list-style-type: none"> • Kit riscaldatore cella per climi freddi • Kit spia passaggio liquido • Kit antigelo scarico condensa • Kit pressostato di bassa pressione • Kit sicurezza compressore (obbligatorio per R404a) 	<ul style="list-style-type: none"> • Cell heater kit for cold climates • Liquid flow sight kit • Condensation drain antifreeze kit • Low pression switch kit • Compressor safety kit (compulsory for R404a)

Ogni componente può essere acquistato singolarmente / Each component can be purchased individually

Dati tecnici nominali		Nominal technical data		FROSTY 2000																		
• Tensione alimentazione	• Working voltage	12 V / 220 V		• Potenza frigorifera • Cooling capacity	<table border="1"> <thead> <tr> <th></th> <th></th> <th>0° C</th> <th>-20° C</th> </tr> </thead> <tbody> <tr> <td rowspan="2">R134a</td> <td>12 V</td> <td>1895 W</td> <td rowspan="2">/</td> </tr> <tr> <td>220 V</td> <td>1494 W</td> </tr> <tr> <td rowspan="2">R404a</td> <td>12 V</td> <td>2366 W</td> <td>1140 W</td> </tr> <tr> <td>220 V</td> <td>1742 W</td> <td>781 W</td> </tr> </tbody> </table>			0° C	-20° C	R134a	12 V	1895 W	/	220 V	1494 W	R404a	12 V	2366 W	1140 W	220 V	1742 W	781 W
		0° C	-20° C																			
R134a	12 V	1895 W	/																			
	220 V	1494 W																				
R404a	12 V	2366 W	1140 W																			
	220 V	1742 W	781 W																			
• Assorbimento elettrico	• Power consumption	10 A (12 V) / – A (220 V)																				
• Portata aria	• Air flow	800 m ³ /h																				
• Refrigerante	• Coolant	R134a / R404a																				
• Peso refrigeratore	• Refrigerator weight	11 kg																				

La nostra società si riserva il diritto di migliorare e modificare ciascuno dei modelli illustrati, senza alcun preavviso.
 Notre Société se réserve le droit d'améliorer et de modifier sans aucun préavis chacun des modèles ci-illustrés.
 The company reserves the right to modify any design in the model without prior notice as per our policy of continuous improvement of design, quality and performance.
 Unsere Firma behält sich das Recht vor, jeden Modell hier erlautet ohne Vorankündigung zu ändern und verbessern.
 La compañía se reserva el derecho a modificar cualquier diseño en los modelos sin previo aviso debido a la política de continua mejora en el diseño, en la calidad y en el rendimiento



Autoclima S.p.A. - 10020 Cambiano (TO) - ITALY
 Via Cavalieri di Vittorio Veneto, 15 - Tel. 011.94.43.210 - Fax 011.94.43.230
 Internet: <http://www.autoclima.com> e-mail: sales@autoclima.com

STAMPATO IN ITALIA - RIPRODUZIONE VIETATA

Cod. 80819208