



AUTOCLIMA
QUALITY & COMFORT

GRUPPO FRIGORIFERO

FROSTY 800



830W

DENVER
AIR CONDITIONERS



Il gruppo frigorifero FROSTY 800 garantisce la temperatura ideale al trasporto delle derrate alimentari, secondo la normativa A.T.P, nelle celle isoterme dei veicoli commerciali di piccole dimensioni. L'evaporatore da montare sotto tetto o a parete, è abbinato ad un gruppo motocondensante installato sul tetto.

Disponibile in versione MARCIA con funzionamento 12V o MARCIA-SOSTA con funzionamento 12V + 220V.

Il pannello di controllo è da posizionare nell'abitacolo.



FROSTY 800 refrigeration unit guarantees the ideal temperature for shipping foodstuffs meeting the A.T.P rule, in isothermic cells of small dimensions vehicles. The evaporator under roof or wall mounted, is combined with a roof top motorcondensing unit.

Available in two versions: one working when vehicle is RUNNING (12V), one working also in STAND-BY (220V). The control panel should be installed in the cab.



FROSTY 800

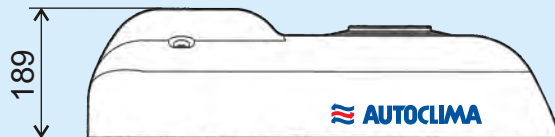
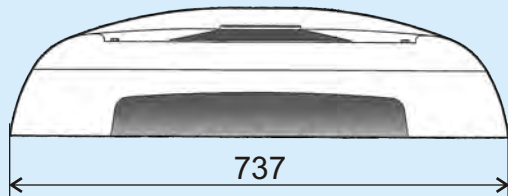

12V cod.12121658.1
12V - 220V cod.12121647.1

**GRUPPO MOTOCONDENSANTE
MOTORCONDENSING UNIT**

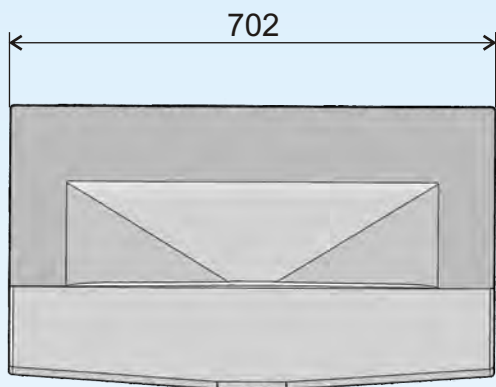
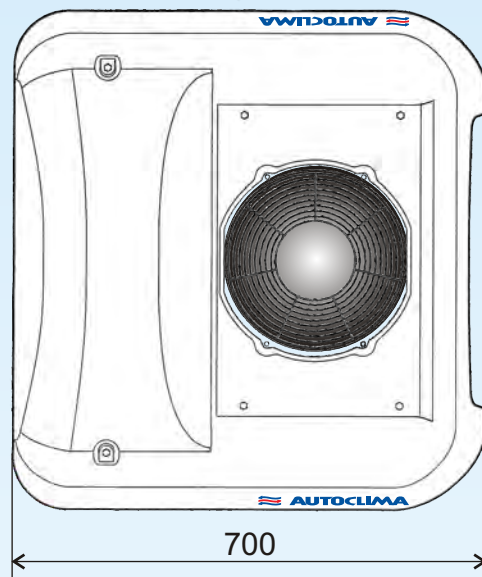

**EVAPORATORE
EVAPORATOR**

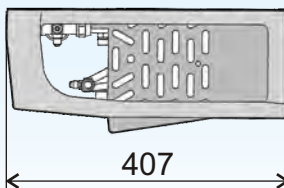

**CENTRALINA DIGITALE
DI CONTROLLO
DIGITAL CONTROL UNIT**

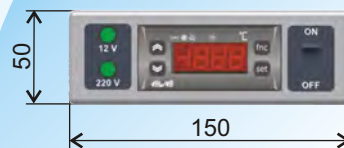

MONTAGGIO TETTO / ROOF MOUNTED MONTAGGIO PARETE * / WALL MOUNTED *

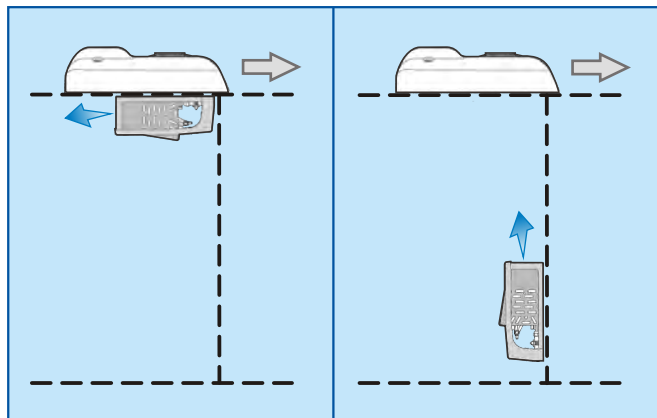

* Cablaggio prolunga cod. 80821183.1 e tubi fornibili a richiesta
* Extension wiring code 80821183.1 and hoses supplied upon request

DATI TECNICI

TECHNICAL DATA

FROSTY 800

• Potenza frigorifera 12V	• 12V cooling capacity	830 W 0°C / 277 W -20°C
• Potenza frigorifera 220V	• 220V cooling capacity	571 W 0°C / 249 W -20°C
• Portata aria evaporatore	• Evaporator air flow	700 m ³ /h
• Funzionamento marcia	• Drive working voltage	12 V
• Funzionamento sosta	• Stand by voltage	220 V
• Refrigerante	• Coolant	R134a
• Assorbimento elettrico	• Power consumption	12V : max 50A
• Peso evaporatore	• Evaporator weight	10 Kg
• Peso condensatore	• Condenser weight	45 Kg
• Sbrinamento	• Defrost	Gas caldo / Hot gas
• Omologazione A.T.P.	• A.T.P. Omologation	Si / Yes

La nostra società si riserva il diritto di migliorare e modificare ciascuno dei modelli illustrati, senza alcun preavviso.
The company reserves the right to modify any design in the model without prior notice as per our policy of continuous improvement of design, quality and performance.



Autoclima S.p.A. - 10020 Cambiano (TO) - ITALY
Via Cavalieri di Vittorio Veneto, 15 - Tel. 011.94.43.210 - Fax 011.94.43.230
Internet: <http://www.autoclima.com> e-mail: sales@autoclima.com

STAMPATO IN ITALIA - RIPRODUZIONE VIETATA

Cod.80819201